

Content

1. ERIKS operating companies
2. Product description
3. Requirements for maintenance staff
4. Transport and storage
5. Function
6. Application
7. Installation
8. Maintenance
9. Service and repair
10. Troubleshooting
11. Removal

1. ERIKS operating companies

ECON lift type check valves are being delivered by several ERIKS operating companies on a worldwide basis. In this manual these will be referred to as 'ERIKS', the individual terms of delivery of the ERIKS operating company having executed the order are applicable.

2. Product description

The ECON lift type check valves are designed according to the information in our latest catalogue or see our website www.eriks.com and should be used in accordance with the applicable pressure-temperature rating as stated on this website. ECON lift type check valves are provided with casted markings according to EN 19. The marking makes the identification of the valve easier and contains:

- size (DN)
- pressure rating class
- body material marking
- arrow, indicating the medium flow direction
- ECON logo

3. Requirements for maintenance staff

The staff assigned to assembly, operating and maintenance tasks should be qualified to carry out such jobs and in any circumstance, ensure personal safety

4. Transport and storage

Transport and storage should always be carried out with the disc completely closed and the valve should be protected against external forces, influence and destruction. The valves should be stored in an unpolluted space and should also be protected against all atmospheric circumstances. There should be taken care of the temperature and humidity in the room, in order to prevent condensate formation.

5. Function

ECON lift type check valves are designed to prevent back flow. The flowing medium presses against the disc, thereby pushing it open. The lift type check valve must be installed horizontal or vertical (upward flow).

6. Application

ECON lift type check valves are used aboard ships but also in installations where corrosion is undesirable.

The installation designer is responsible for the check valve selection, suitable for the working conditions. The valves are unsuitable, without written permission of an ERIKS company, to apply for hazardous media as referred into Regulation (EC) No 1272/2008.

7. Installation

During the assembly of the ECON lift type check valves, the following rules should be observed:

- make sure before an assembly that the valves were not damaged during the transport or storage.
- make sure that the applied valves are suitable for the working conditions, medium used in the plant and the right system connections, according to pressure and temperature limits.
- the lift type check valves (e.g. Fig.496) standard with spring, can be installed in a horizontal or vertical pipeline, but only with rising flow.
- during fitting, the proper flow direction has to be considered.
- during fitting the location of the valve, after a bend or pump, must be at least 5xDN in a straight line. Also after the valve, a straight line of 2xDN is recommended. This to avoid too much turbulence in the check valve, which may causes malfunctioning and or rattling of the disc.
- the interior of the valve and pipeline must be free from foreign particles.
- the valve should be assembled in the pipeline in closed position, for a correct functioning, the valve must be stress free mounted between the flanges, supports must be arranged to prevent any additional stress, caused by the weight of the valve or the pipeline.
- bolted joints on the pipeline must not cause additional stress resulted from excessive tightening, user shall select proper bolts and gaskets according the working temperature, working pressure and medium.
- before plant startup, especially after repairs carried out, flash out the pipeline.
- after installation it is necessary to check the valve operation and tightness of all connections. A tightness test should be carried out.

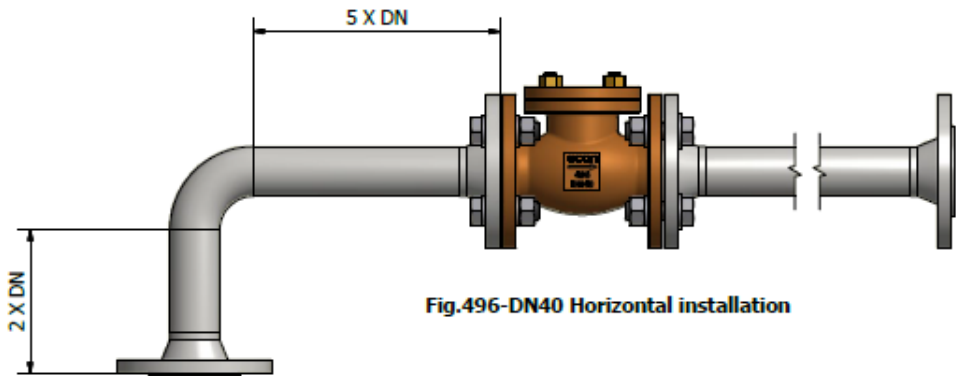

Fig.496-DN40 Horizontal installation

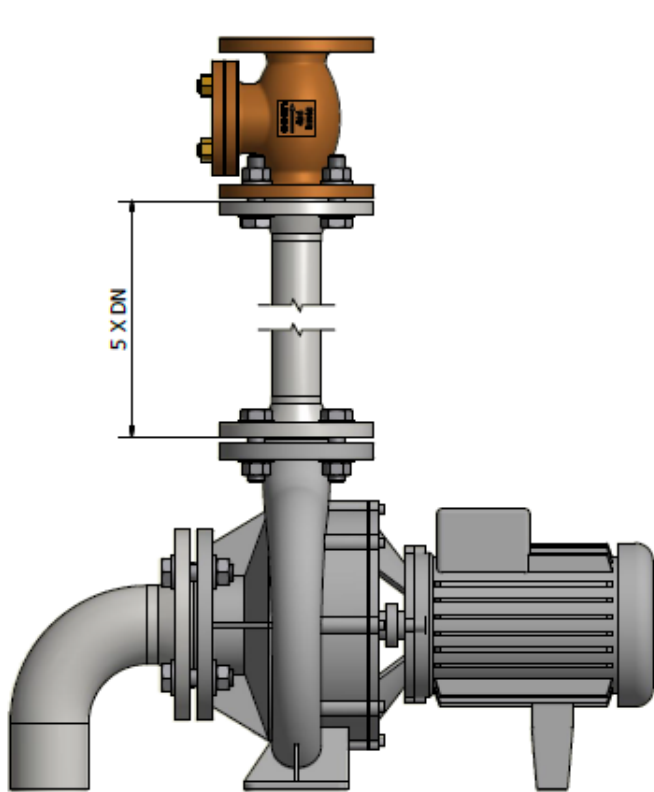

Fig.496-DN40 Vertical installation after pump

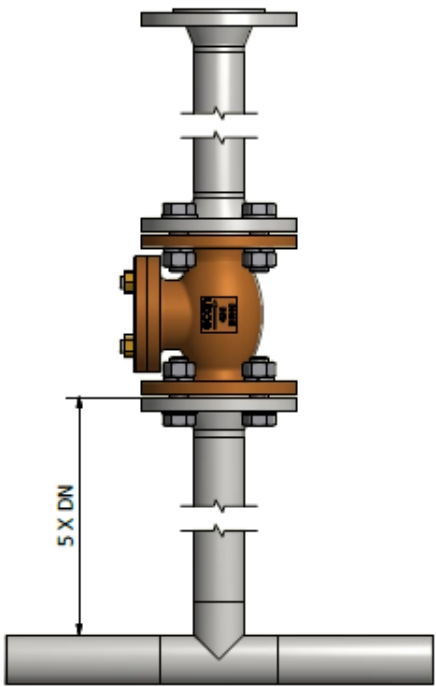

Fig.469-DN40 Vertical installation after bend

8. Maintenance

Before starting any service jobs, make sure that the medium supply to the pipeline is cut off, pressure was decreased to ambient pressure, the pipeline is completely cleaned and ventilated and the plant is cooled down. Always keep safety instructions in mind and take all personal safety precautions.

During maintenance, the following rules should be observed:

- always keep personal safety precautions in mind and always use appropriate protection e.g. clothing, masks, gloves etc.
- be alert that the temperature still can be very high or low and can cause burns.
- check the valve on all possible leaking possibilities.
- check if all bolts and nuts, are still fastened.
- check if the disc still opens and closes in a proper manner.
- the thickness of the body must be checked to ensure safety operation at an interval of at least three months.

9. Service and repair

All service and repair jobs should be carried out by authorized staff, using suitable tools and user shall use valve gasket, bolt and nut of the same size and material as the original one.

- weld repair and drilling of the valve is forbidden.
- it is forbidden to replace the bolt, nut or packing when the valve is under pressure.
- tighten the hexagon nuts evenly crosswise in the there for standard order.
- after replacement of the gasket, bolts or nuts, it is necessary to check the valve operation and tightness of all connections. A tightness test should be carried out.
- after installation, the valve should be checked and maintained periodically at least every 3 months, depending on the medium.

10. Troubleshooting

It is essential that the safety regulations are observed when identifying the fault.

Problem	Possible cause	Corrective measures
No flow	Valve is installed in the wrong way	Arrow of flow direction has to run in the same direction as the flow itself
Little flow	Disc does not completely open	Check disc opening function
	Piping system clogged	Check piping system
Leakage across valve seat	Disc not properly closed	Check disc opening function
	Seat damaged by foreign particles	Replace the valve
	Deformation of disc by hammer blow	Replace the valve
Rattling/banging of the disc	Nominal diameter of the valve in relation to the flow rate is too big	Choose smaller nominal diameter
	High flow speed	Change the system
	After a 90 ° bend in the pipe	
	Expansion joints are missing	
	There is no stabilizing pipe length	
There is no start-up bypass line		
Body broken and leaking	Water hammer	Replace the valve
	Broken because of freezing	Replace the valve and drain the water in the winter when the valve is not used

11. Removal

All dismantled and rejected valves cannot be disposed with household waste. The valves are made of materials which can be re-used and should be delivered to designated recycling centers.

General warning:

General note for products which may be used for seawater:

Although our products can be used in seawater systems it should always be noted that, in case of installation in a piping system made of materials which are frequently used because of their excellent seawater resistance (e.g. Cunifer), large potential differences may occur possibly causing corrosion which could permanently damage the proper functioning and integrity of our product.

A combination of different materials should always be mentioned prior to the purchase of our products in order for us to give the best possible advise on a safe functioning.